

# REPAIR PARTS CATALOG



## TRANSPORT PULVI-MULCHER

Model M-148  
Model MC-148  
Model MCC-148  
Model MCR-148  
Model MD-148  
Model MDC-148  
Model MDCC-148  
Model MDCR-148

IMPORTANT! Repairs cannot be purchased retail direct from factory. Order through your Brillion dealer.

**BRILLION IRON WORKS  
BRILLION, WISCONSIN 54110**

MODEL # NAME PLATE IS LOCATED ON  
REAR CHANNEL. SEE PAGE 2.

MODEL NO.  
DATE PURCHASED

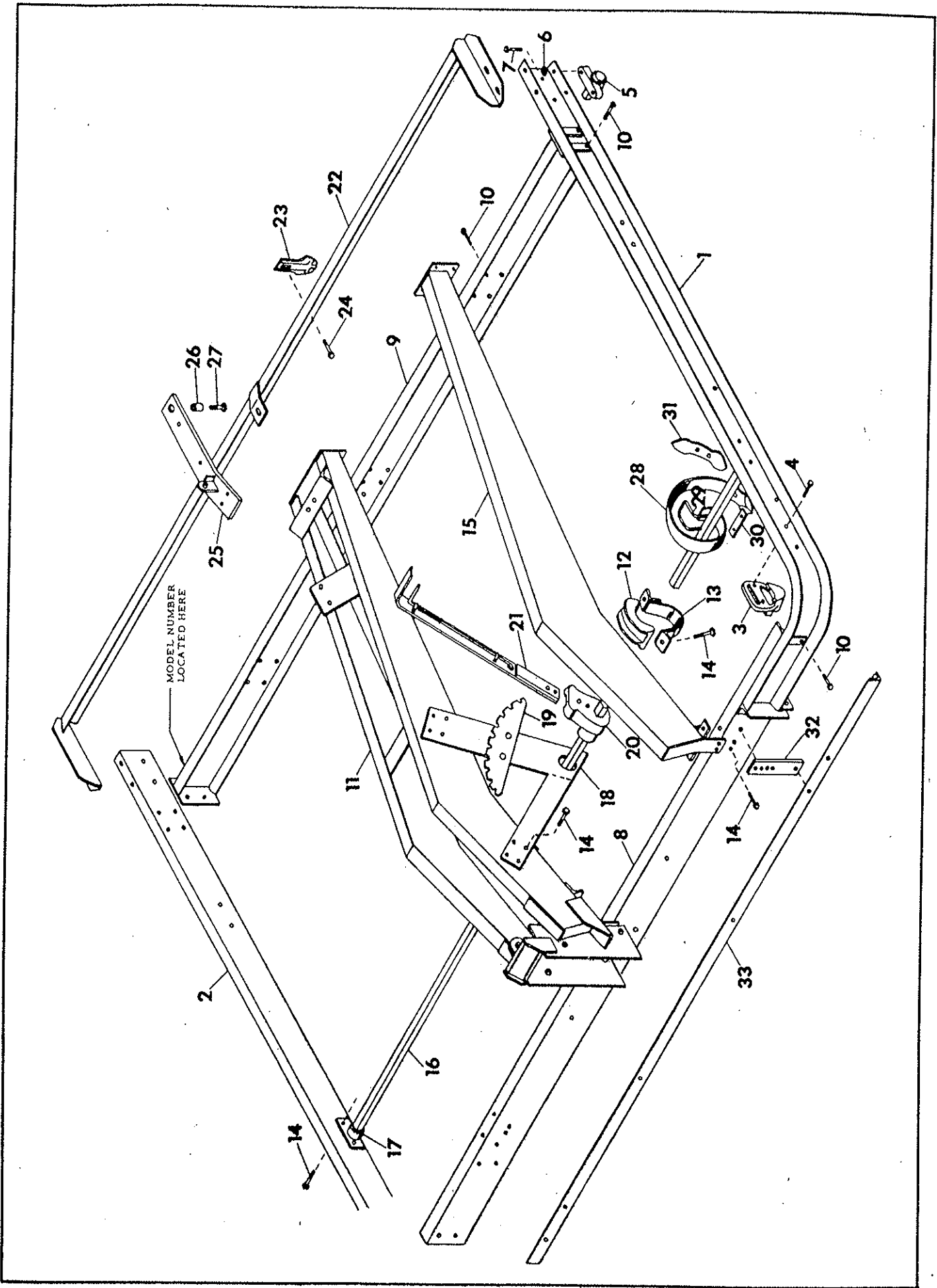

M-148 TRANSPORT PULVI-MULCHER

Index No.	Part No.	Part Name	No. Used	Weight
1	4D-44	L. H. Channel Assembly	1	70.0
2	4D-46	R. H. Channel Assembly	1	70.0
3	1J-176	Long Axle Mount	2	5.5
4	1D-237	Capscrew, 1/2-13 NC x 2" Lg., Grade 5	12	
	1C-109	Lockwasher, 1/2" Med.	57	
	1C-390	Nut, 1/2-13 NC	57	
5	9D-672	Short Axle Mount	2	7.0
6	7C-22	Bevel Washer	12	
7	7C-875	Capscrew, 1/2-13 NC x 2-1/2" Lg., Grade 5	4	
8	4D-448	Front Channel Assembly	1	98.0
9	4D-444	Rear Channel Assembly	1	106.1
10	2D-474	Capscrew, 5/8-11 NC x 1-3/4" Lg., Grade 5	33	
	1B-166	Lockwasher, 5/8" Med.	33	
	1C-392	Nut, 5/8-11 NC	33	
11	1J-201	Center Truss Assembly	1	148.0
12	1J-269	Bearing Cap Assembly	4	4.6
13	1J-194	Bearing Yoke	4	2.5
14	8C-527	Capscrew, 1/2-13 NC x 1-1/2" Lg., Grade 5	36	
15	1J-212	L. H. Truss Frame Assembly	1	51.0
	1J-213	R. H. Truss Frame Assembly (not shown)	1	51.0
16	9C-517	Spring Tooth Shaft	2	95.8
17	1J-505	Front Spring Tooth Shaft Bearing Assembly	2	1.3
	4D-163	Rear Spring Tooth Shaft Bearing Assembly	2	1.3
18	1J-498	Front Spring Tooth Shaft Support	1	16.8
19	3J-165	Front Spring Tooth Quadrant	1	6.0
	5D-27	Rear Spring Tooth Quadrant	1	5.7
20	4D-180	Front Center Bearing	1	9.9
	7C-309	Set Screw, 3/8-16 NC x 1-1/4" Lg. Sq. Hd.	1	
	7C-259	Rear Center Bearing (not shown)	1	8.8
	7C-427	Set Screw, 3/8-16 x 1-3/4" Lg. Sq. Hd.	1	
21	6C-956	Lift Handle Assembly	2	10.3
	5D-667	Capscrew, 3/8-16 NC x 2-1/2" Lg. Grade 5	4	
	1C-183	Lockwasher, 3/8" Med.	42	
	1C-277	Nut, 3/8-16 NC	42	
22	5D-309	Scraper Bar	1	88.0
23	2D-110	Scraper	37	1.0
	3D-627	Center Scraper	1	
24	3C-734	Carriage Bolt, 3/8-16 NC x 1-1/2" Lg.	38	
	1C-182	Flat Washer, 3/8" Std.	38	
25	4D-106	Dolly Drawbar	1	17.5
26	5D-312	Spacer	1	.4
27	1C-234	Capscrew, 1/2-13 NC x 2" Lg.	5	
	1C-120	Flat Washer, 1/2" Std.	6	
28	5C-4	Spring Tooth (7/16" x 2" Wide)	23	9.5
29	8C-384	Clamp Bolt	23	.3
30	5C-78	Clamp Strap	23	.7
	1C-109	Lockwasher, 1/2" Med.	46	
	1C-390	Nut, 1/2-13 NC	46	
31	4D-386	Reversible Shovel (Can be used on worn 5C-4 spring tooth)		1.1
	2C-628	Plow Bolt, 3/8-16 NC x 1-1/2" Lg., R. H. Sq. Neck C. S.		
32	9D-14	Leveler Support (Optional)		3.1
33	9D-22	Leveler (Optional)		54.0

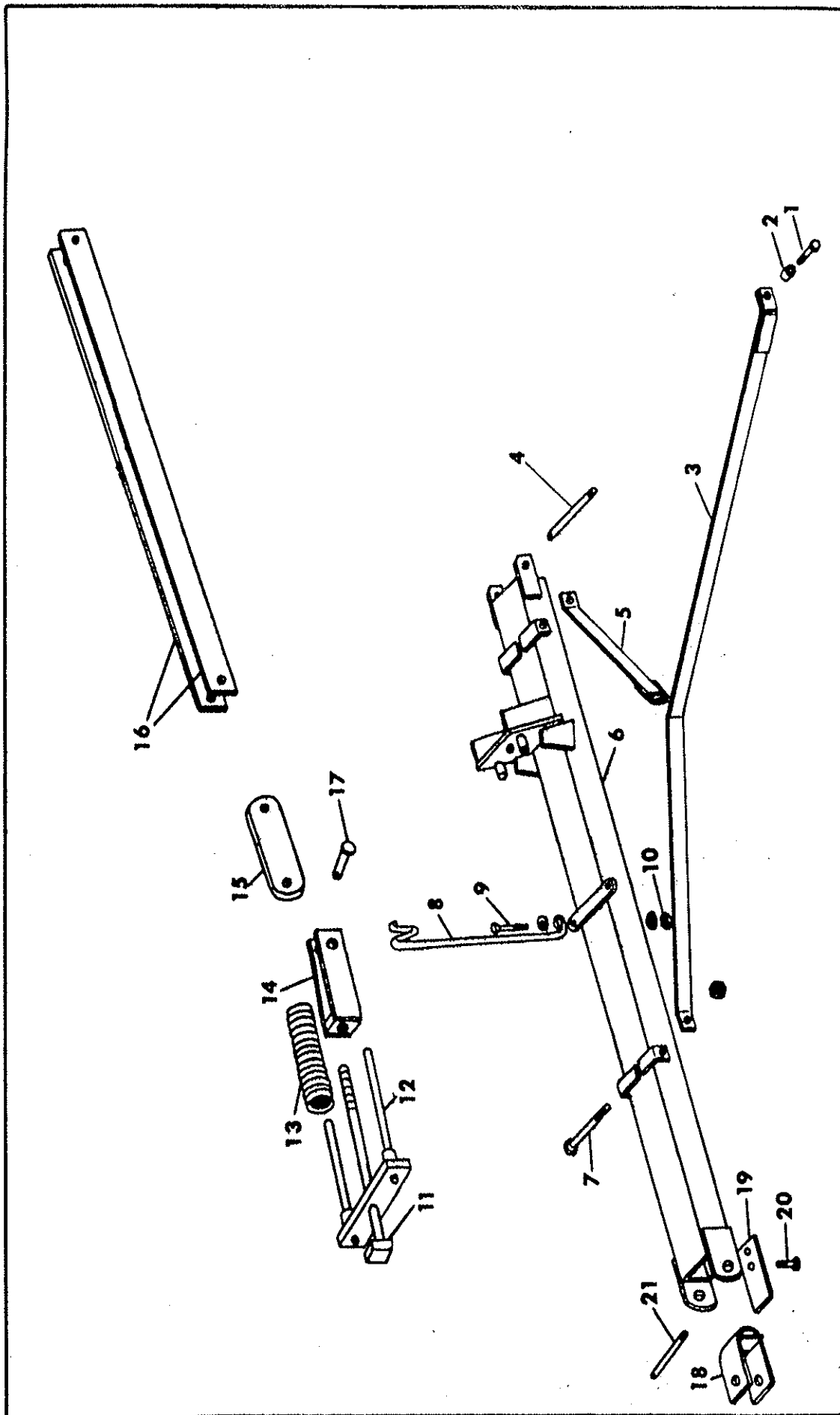

M-148 TRANSPORT PULVI-MULCHER

Index No.	Part No.	Part Name	No. Used	Weight
1	7C-875	Capscrew, 1/2-13 NC x 2-1/2" Long, Grade 5	2	
	1C-109	Lockwasher, 1/2" Med.	4	
	1C-390	Nut, 1/2-13 NC	4	
2	4D-778	Drawbar Pivot Bushing	2	.2
3	4D-728	Drawbar Brace	2	14.4
4	4D-100	Drawbar Mounting Pin	1	1.5
	4C-446	Cotter Pin, 1/4 Dia. x 1-1/2" Long	4	
5	4D-75	Drawbar Brace	2	4.3
6	6D-873	Drawbar	1	80.0
7	3C-910	Hex Head Machine Bolt, 1/2-13 NC x 6-1/2" Lg., Gr. 5	2	.8
8	6D-333	Hose Support	1	1.8
9	5C-460	Capscrew, 5/8-11 NC x 2" Long, Gr. 5	1	
	5C-907	Flat Washer, 5/8" S. A. E.	1	
	1B-166	Lockwasher, 5/8" Med.	1	
10	5C-461	Nut, 5/8-11 NC, Hex Stover	1	
11	6D-877	Sq. Head Machine Bolt, 3/4-10 NC x 10" Long	1	1.5
12	6D-870	Spring Guide	1	4.0
13	6D-828	Spring	2	5.0
14	4D-66	Yoke	1	2.3
15	6D-868	1/2" Strap	1	2.4
16	6D-872	1/4" Strap	2	5.1
17	2D-473	Clevis Pin, 3/4 x 1-7/8" Long	3	.3
	1C-205	Cotter Pin, 5/32 Dia. x 1-1/2" Long	3	
18	6D-879	Clevis	1	8.0
19	6D-865	Flat Spring	1	.2
20	6C-379	Capscrew, 3/8-16 NC x 7/8" Long	2	
	1C-183	Lockwasher, 3/8" Med.	2	
	5C-954	Locknut, 3/8-16 NC, Grade B, Stover	2	
21	6D-944	Drawbar Mounting Pin, 1" Dia. x 6-1/4" Long	1	1.3

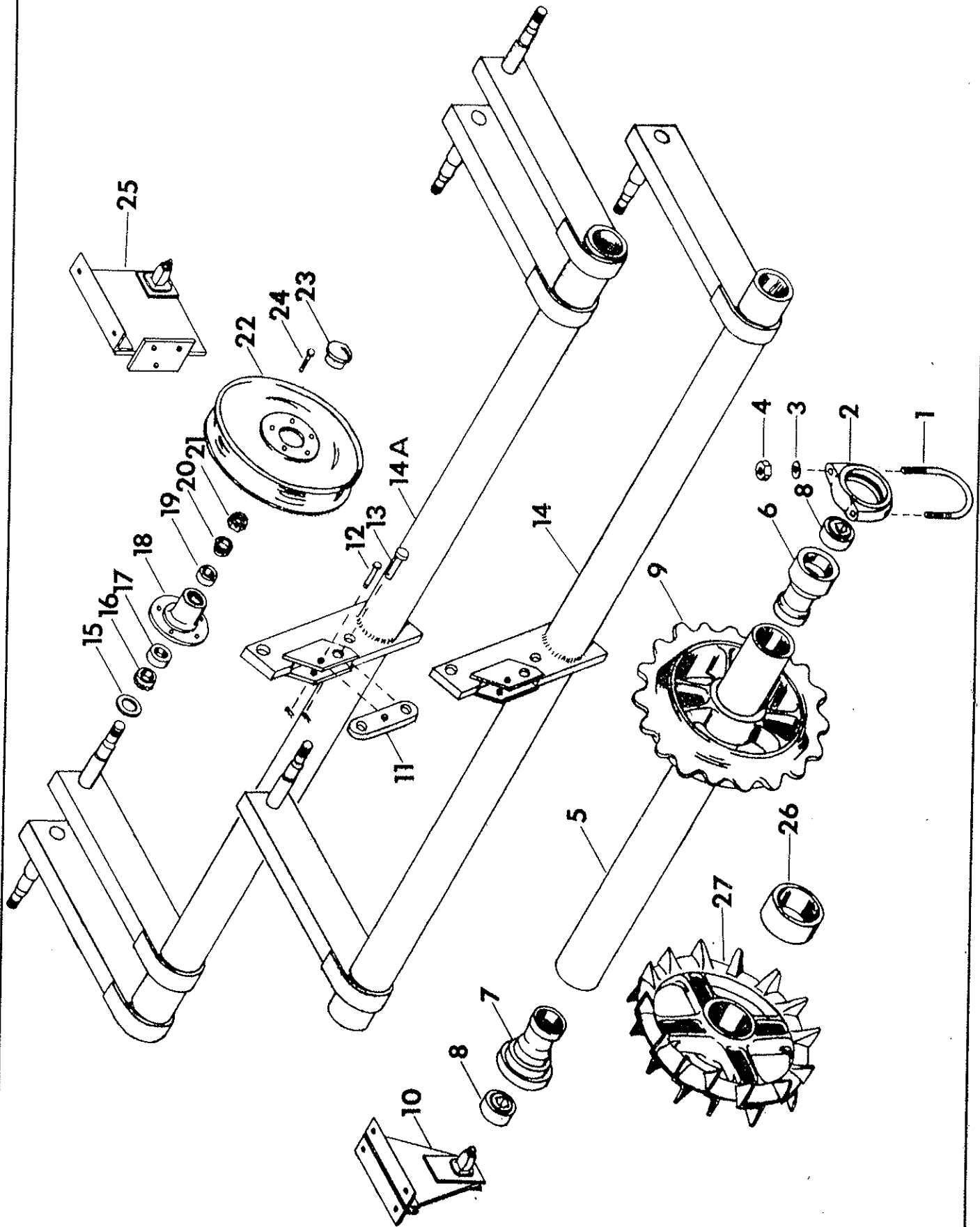

M-148 TRANSPORT PULVI-MULCHER

Index No.	Part No.	Part Name	No. Used	Weight
1	9D-673	U-Bolt	4	.7
2	9C-31	Axle Clamp	4	3.7
3	1C-109	Lockwasher, 1/2" Med.	8	
4	1C-390	Nut, 1/2-13 NC	8	
5	8C-986	Pipe Axle Assembly - 72-5/16 Long - Includes Bearings	3	69.0
	9C-506	Pipe Axle Assembly - 76-5/16 Long - Includes Bearings	1	72.0
6	9C-14	Outer Bearing Housing	4	7.0
7	9C-15	Inner Bearing Housing	4	8.0
8	9C-16	Bearing	8	1.7
9	8C-988	Pulverizer Wheel	73	34.0
10	1J-373	Front Center Bracket Assembly	1	14.8
	1J-371	Front Center Bracket	1	
	9D-669	Straight Axle Mount	2	
	9D-866	Drilled Bolt, 5/8-11 NC x 6" Long, Grade 5	1	
	1B-166	Lockwasher, 5/8 Med.	1	
	4D-529	Slotted Nut, 5/8-11 NC	1	
	2C-864	Cotter Pin, 1/8-1" Long	1	
11	1J-203	FloaT Link	1	4.5
12	8C-520	Clevis Pin, 1/2 Dia. x 2-1/2" Long	1	
	4C-856	Hairpin Cotter	1	
13	8D-99	Clevis Pin, 1" Dia. x 2-1/2" Long	1	
	1C-788	Cotter Pin, 3/16 x 1-1/2" Long	1	
14	1J-421	Transport Axle Assembly - Complete	1	240.8
14A	1J-420	Dual Wheel Transport Axle Assembly - Complete (Painted Red)	1	375.8
15	1D-273	Grease Seal	2	.1
16	5C-480	Bearing Cone (#LM48548)	2	.2
17	5C-479	Bearing Cup (#LM48510)	2	.2
18	1J-390	Hub	2	8.6
19	5C-912	Bearing Cup (#LM11910)	2	.2
20	5C-911	Bearing Cone (#LM11949)	2	.3
21	3C-173	Slotted Nut, 3/4-16 NF, Light	2	.1
	3C-350	Cotter Pin, 5/32 x 1" Long	2	
22	4C-129	Wheel (15" Rim) (Standard)	2	16.0
	1D-734	Wheel (14" Rim) (Optional)	2	16.0
23	1J-463	Hub Cap	2	.8
24	5C-100	Wheel Bolt	10	.1
25	1J-374	Rear Center Bracket Assembly	1	21.3
	1J-367	Rear Center Bracket	1	

USED ON MC, MCC & MCR PULVI-MULCHERS

26	2D-213	Spacer - 2-3/16 Wide (Used on 72-5/16 Long Pipe Axle Assembly)	MC	22	3.0
			MCC	33	
			MCR	11	
9	4D-108	Spacer - 2-1/16 Wide (Used on 76-5/16 Long Pipe Axle Assembly)	MCC	12	2.8
			MCR	12	
			MC	37	
27	1D-927	Crowfoot Wheel	MCR	36	34.0
			MCC	49	
			MCR	25	
			MC	24	